



# MEWPs Safe Use Plan Development Guide



MOBILE ELEVATING WORK PLATFORM (MEWP)

# Safe Use Plan Development Guide

**NOTE: This MEWP Safe Use Plan Development Guide is intended for use as an information source to assist users of MEWPs in creating their own site and equipment-specific MEWP Safe Use Plan as required by ANSI A92.22 and CSA B354.7 MEWP safety standards. The information contained within this guide is general in nature and provided for reference only. On its own, it does not constitute a complete safe use plan as prescribed by the aforementioned standards.**

## Introduction

The operation of any Mobile Elevating Work Platforms (MEWP) is subject to certain hazards that can be protected against only by the exercise of knowledge gained through comprehensive training, careful operation and good judgement. No device or system can effectively replace those three items. It is vital to select personnel who are capable in both mind and body to work on, or with MEWPs safely and competently.

In addition, informed operational management, safety planning and the implementation of recognized principles of safety training, inspection, maintenance, repair, application and operation must be consistently adhered to at all times to help ensure the avoidance of injury and/or damage-producing incidents.

Information from all related sources on the intended use and the work environment must be considered. Decisions on the use and operation of MEWPs must always be made with consideration of the fact that a MEWP carries people whose safety is dependent on those decisions, as well as others in the operating area.

With that in mind, a MEWP-specific safe use program must be developed by the user and include the following items such as but not limited to:

- a) Performing a site risk assessment to identify hazards, evaluate risk, develop control measures and communicate the findings and safety procedures developed to everyone affected;
- b) Planning operations, including rescue plans for the safe and timely recovery of personnel and/or the MEWP in the event of an emergency;
- c) The selection, provision and use of a suitable MEWP for the task as well as any other required equipment related to it;
- d) Access, preparation and maintenance of the site to ensure that the support surface to and from the task is capable of safely supporting the weight of the MEWP;
- e) MEWP maintenance, including inspection(s) and repairs as required in accordance with the applicable standards and the manufacturer;
- f) Authorizing only trained and qualified personnel to operate and/or occupy a MEWP;
- g) Ensuring that MEWP operators are familiarized with the specific MEWP to be used;
- h) Ensuring that the operators are informed of local site requirements and provided with the means to protect against identified hazards in the areas where the MEWP will be operated;

- i) Ensuring supervisors are trained and qualified to monitor MEWP operations including the performance of the operators to ensure compliance with the applicable standards;
- j) Prevention of unauthorized use of the MEWP;
- k) The safety of persons not involved in the operation of the MEWP; and
- l) Proper documentation and record retention.

Specific information on the requirements can be found in current versions of ANSI A92.22 for the Safe Use of Mobile Elevating Work Platforms (MEWPs) and CAN/CSA B354.7 Mobile Elevating Work Platforms – Safety principles, inspection, maintenance and operation standards applicable across the USA and Canada as follows:

<b>MEWPs Standards Compliance Requirements by Region</b>			
<b>Region</b>	<b>ANSI</b>	<b>CSA</b>	<b>ANSI/CSA</b>
United States (All)	✓		
Canada (Federally regulated worksites)		✓	
Alberta			✓
British Columbia			✓
Manitoba		✓	
Newfoundland/Labrador			✓
New Brunswick		✓	
Northwest Territories			✓
Nova Scotia		✓	
Nunavut Territory			✓
Ontario		✓	
Prince Edward Island		✓	
Saskatchewan			✓
Quebec			✓
Yukon Territory		✓	
<b>NOTE: Check regional regulations, codes and/or standards as local requirements may differ from the above.</b>			

## MEWPs Site Risk Assessment

A site risk assessment is a critical element of an overall MEWP safe use plan. When the risks associated with the task specific to MEWP operations are identified and dealt with before the work begins, it goes a long way toward helping to ensure worker safety and reducing the probability of damage and/or injury-producing incidents. With that in mind, it's important to consider items that may be associated with the location and nature of the work to be carried out, the type of MEWP, and the personnel, materials and/or related equipment to be used.

Start by inspecting the location where the work is to be done, preferably with other personnel who are knowledgeable of the site. Focus on identifying any potential hazards in the area and assess the ground on which the MEWP will travel and/or operate.

The next step is to develop control measures and implement safe work procedures that eliminate or lessen the risks posed by the hazards identified.

Rescue planning is also a huge consideration and a vital component of a MEWP operations-related site risk assessment as workers will be working at height and may be subject to situations where timely rescue is critical. Rescue planning is discussed later in this document.

The *user*, also referred to as the *employer* in this guide, is responsible for communicating the results of their site risk assessment and the related safe work procedures to everyone directly and indirectly involved in the MEWP operation.

Before the start of work and at appropriate intervals throughout a long-term job, the site risk assessment must be reviewed and updated if any components of the task(s) or the work environment(s) that could affect safe MEWP operations have changed. Of course, any updates to the site risk assessment must also be communicated to everyone affected by them immediately. Refer to the SAMPLE MEWP Site Risk Assessment on the following page and use it to help develop your safe use plan.

### SAMPLE MEWPs Site Risk Assessment (SUP-183-e):

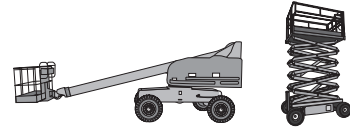

MEWPs Site Risk Assessment		
Company Name: <i>ABC Industries Inc.</i>		Date: <i>March 1, 2025</i>
Worksite Location: <i>1234 Marine St., Anytown, WA 98230</i>		
Assessor Name(s) & Contact Info: <i>Pat Strickland 206-321-0987 / Terry Crisp 360-798-2314</i>		
HAZARD	RISK	CONTROL MEASURE
1 <i>Power lines nearby</i>	<i>Electrocution</i>	<ul style="list-style-type: none"> <li>• Turn off/re-route power.</li> <li>• Maintain safe distance as required (see MFD chart).</li> </ul>
2 <i>Pedestrian traffic</i>	<i>Contact/Crushing</i>	<ul style="list-style-type: none"> <li>• Rope off area from pedestrians.</li> <li>• Hi-visibility PPE for all.</li> <li>• Carefully inspect area before any MEWP movements.</li> </ul>
3 <i>Ground is sloped in areas</i>	<i>Tip-over</i>	<ul style="list-style-type: none"> <li>• Confirm gradeability of MEWP as per manufacturer and ensure unit is appropriate.</li> <li>• Do not elevate on a slope.</li> <li>• Ensure slope MEWP slope warning device operational.</li> </ul>
4 <i>Possible wind</i>	<i>Tip-over</i>	<ul style="list-style-type: none"> <li>• Take steps to determine wind speed.</li> <li>• Cease operations if wind speed could exceed unit specs.</li> </ul>
5		
6		
7		

**NOTE: Blank/Fillable copies of this form available at [www.ivestraining.com](http://www.ivestraining.com).**

## Worksite Inspection

Operators must perform a worksite inspection of the area the MEWP is to be used in before the start of operation and thereafter as required. To be clear, the planned travel route to and from the work location as well as the work location itself must be inspected before the MEWP is moved. Refer to the SAMPLE MEWP Worksite Inspection on page 9.

When conducting worksite inspections, consider the following items and protective measures such as but not limited to:

- a) Drop-offs or holes, including those concealed by water, ice, mud, etc.
  - i. Thoroughly inspect the work area and the travel route to and from the work location where the task or tasks are to be performed.
  - ii. Ensure any drop-offs, like curbs, dips or holes are identified and either cordoned off, marked for avoidance or, in the case of holes, filled in with appropriate material.
  - iii. Consider using spotters/signal-persons to guide operators through areas that contain these hazards.
- b) Slopes
  - i. Plan/Create travel routes that are hard, flat and level wherever possible.
  - ii. Ensure MEWP operators:
    - o Only travel straight up and down slopes that are within the maximum gradeability rating of their unit.
    - o Never turn, zig-zag with the unit while on a slope.
    - o Never position/set up their unit to elevate to a task location while on a slope.
- c) Bumps, floor obstructions and electrical cables
  - i. Choose/Create travel paths that are clear of such hazards.
  - ii. Clear and/or prepare MEWP travel paths such that the road wheels will not ride up on anything that may cause the unit to become non-level.
- d) Debris
  - i. Choose/Create travel paths that are clear of such debris.
  - ii. Clear MEWP travel paths of any sort of debris that the road wheels could ride up on and cause the unit to become non-level.
- e) Overhead obstructions
  - i. Avoid areas with overhead obstructions.
  - ii. Identify and where possible, remove, flag, cordon off such obstructions.
  - iii. Ensure MEWP work platform operators/occupants have protective head gear when working in areas with overhead obstructions.
- f) Electrical conductors
  - i. Avoid areas with electrical conductors.
  - ii. De-energize electrical conductors.
  - iii. Re-route power to/from electrical conductors.
  - iv. Where possible, flag, cordon off electrical conductors.
  - v. Ensure operators maintain the appropriate minimum approach distance (MAD) from electrical conductors.
  - vi. Ensure workers are qualified and MEWPs are electrically insulated.

- g) Hazardous atmospheres and/or locations
  - i. Avoid working in hazardous atmospheres and/or locations.
  - ii. Remove hazardous elements from atmospheres/locations.
  - iii. Ensure appropriate personal protective equipment (PPE) is employed.
  - iv. Ensure appropriately rated/insulated MEWPs are used.
  - v. Ensure emergency response personnel designated (fire, containment, evacuation, rescue, etc.).
- h) Support surface conditions
  - i. Avoid working in areas where surface conditions are inadequate to support ground bearing pressure of MEWP.
  - ii. Initiate steps to increase weight bearing ability of MEWP support surface.
  - iii. Initiate steps to distribute ground bearing pressure of MEWP over a greater area.
  - iv. Select a MEWP with less ground bearing pressure.
- i) Wind and weather conditions
  - i. Be proactive in planning MEWP operations to coincide with fair weather.
  - ii. Ensure weather conditions are observed and considered before authorizing MEWP operations.
  - iii. Ensure weather conditions such as but not limited to wind, rain, freezing temperatures, high temperatures, ice, fog, lightning and other potentially hazardous weather conditions are considered.
  - iv. Discontinue MEWP operations where wind speeds approach/exceed the maximum allowable wind specifications of the manufacturer.
  - v. Discontinue MEWP operations when lightning is observed.
- j) Presence of personnel and other mobile equipment
  - i. Avoid operating in presence of personnel or other mobile equipment.
  - ii. Cordon off/barricade areas from intrusion of pedestrian/vehicle traffic.
  - iii. Employ spotters and/or other traffic control measures to divert transient traffic away from or around areas of MEWP operations.
  - iv. Employ signage and/or other methods to warn transient traffic of the presence of MEWP operations/overhead work.
- k) Traffic hazards (public roadways)
  - i. Avoid operating on public roadways.
  - ii. Ensure traffic cones, signage, flares or other warning devices are used to alert road/highway vehicles and pedestrians to the presence of overhead MEWP operations.
  - iii. Ensure steps above are performed in accordance with all applicable local traffic regulations, bylaws, codes, standards, ordinances, etc.
  - iv. Ensure MEWPs are not left unattended in public areas or where unauthorized access is possible.
  - v. Barricade, lock, disable or otherwise take every precaution to ensure that unattended MEWPs in public areas are inaccessible and/or unusable.

**NOTE: Many damage/injury-producing incidents with MEWPs involve one or several of the items listed above. The importance of identifying and assessing the hazards associated with any of these items during site inspections cannot be emphasized enough as being vital to safe MEWP operation.**

### SAMPLE MEWPs Worksite Inspection (SUP-189-e):

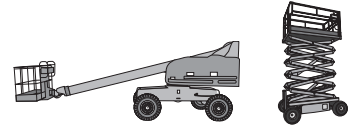

MEWPs Worksite Inspection		
Company Name: <i>Cirrus Construction Ltd.</i>		Date: <i>May 24, 2025</i>
Site Location: <i>Blue River Division</i>		
Inspection Location: <i>East maintenance yard</i>		
Completed by: <i>Terry Kruschelnyski</i>		
Hazard Present	Yes/No ✓/X	Control Measures/Comments
1 Drop-off holes.	X	
2 Slopes.	✓	<i>Barriers placed on access road to yard.</i>
3 Bumps/Floor obstructions.	X	
4 Debris.	✓	<i>Driving path cleared with loader.</i>
5 Overhead obstructions.	✓	<i>Ductwork to/from hopper - MEWP operators advised to travel lowered.</i>
6 Electrical conductors.	✓	<i>Power lines - MEWP operators advised to observe 10-ft MAD</i>
7 Hazardous atmospheres/locations.	X	
8 Support surface conditions.	X	
9 Wind and weather conditions.	X	
10 Presence of personnel/other equipment/traffic.	✓	<i>All personnel advised to stay clear. MEWP work area cordoned off with barrier tape/ traffic cones.</i>
11 Other*	✓	<i>Hotwork on roof of building #2 - MEWP operators advised to stay clear.</i>

**NOTE: Blank/Fillable copies of this form available at [www.ivestraining.com](http://www.ivestraining.com).**

## Worksite Preparation

Worksite preparation involves inspecting the travel route of the MEWP to and from the task as well as the task location itself and taking steps to ensure any hazards related to the ground surface and/or support conditions are corrected before using the MEWP in such travel/work areas. Another important aspect of worksite preparation is the safety of pedestrians in work areas where MEWPs are used. Every effort should be made to control the area below and around the MEWP as people and/or other equipment could be struck by objects that may fall from the elevated work platform of a MEWP or by the actual MEWP.

## Transport

Personnel loading/unloading MEWPs from transport vehicles must ensure appropriate safety measures are taken such as but not limited to the use of:

- a) Traffic/Warning cones and/or hazard tape.
- b) Signs and signal personnel wearing approved high-visibility clothing.
- c) Properly trained flag personnel to warn people and other vehicles of the presence of the MEWP and the transport vehicle, particularly in public areas or roadways.
- d) The transport vehicle:
  - i. Is secure with the wheels blocked and the park brake set.
  - ii. Has a rated load carrying capacity capable of supporting the MEWP.
  - iii. Can provide the required area on the load deck and ramp access to it for MEWP.
- e) The MEWP:
  - i. Is capable of traversing the incline/decline of the transport vehicle loading ramp.\*
  - ii. Is positioned for transport in its stowed (fully lowered and retracted) position.
  - iii. Has its turret rotation lock pin engaged (boomlift).
  - iv. Is shut down with the key removed.
  - v. Is prepared for transport by trained personnel using appropriately rated and properly inspected rigging/tie-down equipment in accordance with the MEWP manufacturer's instructions.
  - vi. Is inspected and cleared of any debris or loose items that may be blown off during transport.

\* Check gradeability rating listed on MEWPs data plate.

## Rescue Planning

In situations where MEWP operators and/or occupants are left suspended in their personal fall protection system following a fall arrest incident, or are stranded on the work platform due to injury, illness or MEWP malfunction/entanglement, they must be rescued in a timely manner.

## Fall Arrest Incident

Even when personal fall protection systems are used correctly, work platform ejection can occur causing injury and the possibility of a condition called *suspension trauma*, which is when blood pools in the legs of a person hanging in a harness after an arrested fall, can occur within a very short period of time. Being suspended in a harness after a fall can result in unconsciousness, followed by death, often in less than 30 minutes. The goal in terms of rescue time is ideally, within five minutes.

Employers are required to have a rescue plan in place and ensure that everyone who is or could be involved in a fall are trained on the procedures to follow if they fall and are awaiting rescue or witness another person fall. The plan must be in writing and become part of your company's training program.

## MEWP Malfunction/Entanglement

In the event of a snagged work platform or unit breakdown that prevents the work platform from being lowered, it is critical to have a plan in place to ensure a timely rescue. A rescue plan is a necessary component of a site risk assessment when working with MEWPs.

Rescue plans should include the following:

- a) Company name and location.
- b) Work site location (if different).
- c) Identification of fall hazards associated with the operation of the MEWP.
- d) Identification of work procedures to eliminate or lessen the risk.
- e) Training on:
  - i. Self-rescue (by the person(s) involved).
  - ii. Assisted rescue (by others in the work area).
  - iii. Technical rescue (by emergency services).

Employers must ensure that:

- a) Only properly trained, qualified and authorized personnel operate the MEWP;
- b) All occupants wear the appropriate personal fall protection equipment (PFPE) for the task at hand; and
- c) All occupants have received instruction on how to properly inspect, don (put on and adjust) and connect the PFPE to a suitable anchorage.

Options for rescue:

- a) Use of work platform controls auxiliary power system by the operator;
- b) Work platform-installed self-rescue systems;
- c) Personal self-rescue systems;
- d) Use of the MEWP emergency ground controls by others in the work area;
- e) Use of the MEWP secondary manual emergency descent controls by others in the work area in the case of complete failure of work platform and emergency ground controls on both primary and auxiliary power;
- f) Use of a rescue MEWP;
- g) Technical rescue by emergency service personnel.

## Options for Rescue – Self-rescue (by the person involved)

### Work Platform Auxiliary Power System

Where the work platform controls stop working while on primary/main power, first the operator should activate the auxiliary power system and re-attempt to use the work platform controls to lower the work platform to the ground.

### Work Platform-installed Self-rescue System

If the work platform controls do not work on main or auxiliary power and there are no other workers in the area who can provide assistance, a work platform-installed self-rescue system, if installed, could be used. These systems are usually after-market devices mounted in the work platform that allow the operator/occupant(s) to self-rescue by attaching the system to the front D-ring on their body harness and exiting the platform using the device to use the controls to lower themselves to the ground.

**NOTE: Users of self-rescue equipment must receive specific training on its use and the approval of the MEWP manufacturer before installing it on the unit. Use of a body holding device (harness) with a sternal D-ring located at the front, chest area is also required.**

### Personal Self-rescue System

These systems can be used to lower an individual from the work platform, or to self-rescue after experiencing a fall or ejection from the platform. They are also after-market devices that can be mounted directly onto the operator's full-body harness. The PFPE lanyard is then attached to the device prior to commencing the work. The system allows the operator to self-rescue by exiting the platform and activating the device to lower themselves to the ground or to within rescue range from another MEWP. Employers that provide personal self-rescue systems for use by employees must ensure such employees receive detailed training in their proper use as per the instructions of the manufacturer.

### Suspension Trauma Safety Straps

These systems attach to the side straps of a personal fall protection full body harness. When hanging suspended in the harness after a fall arrest event, the user releases the straps, adjusts them to the proper length, and steps into the loop(s) created by the straps and "stands" in them relieving the restriction applied to the arteries and veins through the top of the legs and groin area until rescued.

**NOTE: If possible, personnel suspended in a harness, particularly one with out safety straps, should attempt to push off of nearby objects with their legs or continuously move them in a pumping motion (like pedaling a bicycle) to increase blood flow and decrease the likelihood of suspension trauma.**



## Options for Rescue – Assisted Rescue (by others in the work area)

NOTE: Rescue should only be conducted by qualified personnel with the appropriate specific training.

### Emergency (Ground) Controls

In cases where the operator cannot lower the work platform using main or auxiliary power, or if the operator is incapacitated, a person on the ground not working on the MEWP who is trained on the proper use of the emergency (ground) controls of the MEWP must be available to use the emergency ground controls to lower the work platform.

### SAMPLE MEWP Emergency/Rescue Personnel Contact List (SUP-184-e):

MEWPs Emergency/Rescue Personnel Contact List				
	Name	Contact Info	MEWP Qualifications	
			Emergency Controls	Rescue
1	<i>Leland Frost</i>	Tel: 988-212-1655 Radio Channel: 114 Other: <i>l.frost@abc_corp.com</i>	✓	
2	<i>Alicia Garland</i>	Tel: 988-293-0569 Radio Channel: Other: <i>a.garland@abc_corp.com</i>	✓	✓
3	<i>Gurnham Samra</i>	Tel: Radio Channel: 114 Other: <i>Afternoon shift only</i>	✓	✓
4	<i>Dale Bukowski</i>	Tel: Radio Channel: Other: <i>dbun77@outcom.net</i>	✓	
5	<i>Ronny Yip</i>	Tel: 774-405-4564 Radio Channel: Other: <i>ryip@abc_corp.com</i>	✓	✓
6	<i>Terry Lambert</i>	Tel: Radio Channel: 090 Other:	✓	
7		Tel: Radio Channel: Other:		
8		Tel: Radio Channel: Other:		
9		Tel: Radio Channel: Other:		
10		Tel: Radio Channel: Other:		

Emergency: Tel- 911 Radio Channel: \_\_\_\_\_ Email: \_\_\_\_\_

First Aid: Tel- 988-321-4587 Radio Channel: 999 Email: \_\_\_\_\_

Safety Mgr: Tel- 774-609-4759 Radio Channel: 212 Email: thallenbach@abc\_corp.com

Plant Mgr: Tel- 988-398-3927 Radio Channel: 213 Email: gmann@abc\_corp.com

Other: \_\_\_\_\_

\*\*\*\* KEEP ON MEWP/UNIT NO. 41 AT ALL TIMES \*\*\*\*

COPYRIGHT — IVES
SUP-184-E rev. 20-066

NOTE: Blank/Fillable copies of this form available at [www.ivestraining.com](http://www.ivestraining.com).

## Secondary Emergency Manual Descent Controls

In cases where the emergency ground controls are not responding, secondary emergency manual descent controls may be used. These are systems that can be used to lower the work platform using manually operated pumps, valves and/or gravity. If none of these systems work, then on site rescue personnel must be summoned to immediately come to the machine for further assistance.

### Use of a Rescue MEWP

- a) In cases where MEWP operators and/or occupants are stranded on an elevated work platform that cannot be lowered for any reason (malfunction, entanglement, etc.), immediate steps must be taken to remove them from the work platform before any attempts are made to address the reason(s) why the work platform cannot be lowered.
- b) MEWPs that have tipped beyond their center of gravity must be stabilized and secured before attempting any rescue.
- c) Using a rescue MEWP should only be carried out after a thorough site review by a qualified person has been performed and a plan has been created. The plan should take into account the following:
  - i. The rescue machine should be positioned to allow the rescue to be performed without compromising the safety of personnel involved in the rescue;
  - ii. As much as is possible, the work platforms of each MEWP should be positioned at equal height with their access points facing each other and minimal distance gap between them;
  - iii. The power on both machines should be shut off during the transfer;
  - iv. Safeguards should be taken to prevent unintended movement of either platform during the transfer;
  - v. All personnel in the work platform, including the person being rescued, must be wearing the proper fall protection equipment and the lanyard(s) must be attached to the anchor points on the rescue machine before the transfer takes place;
  - vi. The rescue machine must not be overloaded at any time during the rescue. This could mean making more than one trip to complete the rescue; and
  - vii. Always comply with the manufacturer's requirements stated in the operator's manual.

If there is injury, illness or risk of exposure, qualified emergency personnel must immediately be contacted.

## Options for Rescue – Technical Rescue (By Emergency Service Personnel)

In cases of operator illness, injury or risk of exposure, technical rescue may be required:

- a) Any rescue procedure must take into consideration the reason(s) why the work platform cannot be lowered and the need for immediate action;
- b) Although professional rescue/emergency responders are trained in technical rescue, keep in mind that their response time may take too long and the equipment they use may not be the best option or even suitable for your particular situation. Although calling 911 for technical rescue could and should be a part of your company's overall rescue plan, it should never be the only part of it and must be considered as a backup or last resort.

**SAMPLE MEWP Rescue Plan (SUP-188-e):**

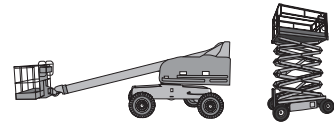

MEWPs Rescue Plan		
Company Name: <i>ABC Industries Inc.</i>		
Worksite Location: <i>1234 Marine St., Anytown, WA 98230</i>		
Date of Rescue Plan Implementation: <i>March 1, 2025</i>		
SITUATION	RESPONSE ADVISED	
1	<i>Work platform controls not working.</i>	<i>Engage auxiliary power system and re-attempt using work platform controls.</i>
2	<i>Work platform controls not working on primary or auxiliary power.</i>	<i>Summon qualified ground personnel to use emergency (ground) controls to lower the work platform.</i>
3	<i>Emergency (ground) controls not working.</i>	<i>Summon qualified ground personnel to use the secondary emergency descent controls to lower the work platform.</i>
4	<i>All emergency (ground) controls not working.</i>	<i>Summon designated site rescue personnel for further assistance.</i>
5		
6		
7		

**NOTE: Blank/Fillable copies of this form available at [www.ivestraining.com](http://www.ivestraining.com).**

## Mobile Elevating Work Platform (MEWP) Selection

MEWPs are available in many different configurations with options and features to suit all sorts of applications and working environments. Choosing the right MEWP for the task and work location is critical in ensuring the work is done efficiently and safely. The following information defines the basic types of MEWPs available and describes what tasks and environments they are best suited for.

### Classifications

MEWP classifications are based on two main elements:

- 1) **Type** – Based on how it travels.
- 2) **Group** – Based on reach; where the center of its work platform is in relation to the unit's tipping line.

### Type

There are three MEWP types:

- 1) **Type 1** – Traveling is allowed only with the MEWP in its stowed (lowered and retracted) position. Drive power is provided by an external source like a tow vehicle (towable units) or a person (push-around units). Units like these are often called *manually propelled* MEWPs.
- 2) **Type 2** – Traveling with the work platform in the elevated position is possible and is controlled from a point on the chassis. Drive power can be provided by an engine or battery.
- 3) **Type 3** – Traveling with the work platform elevated is controlled from a point on the work platform. MEWPs of this type are also powered by engine or battery and often called *self-propelled* MEWPs.

### Group

There are two MEWP groups:

- 1) **Group A** –MEWPs are designed such that the center of the work platform can never go outside of the tipping line or chassis/base dimension.
- 2) **Group B** –MEWPs are designed with work platforms capable of being extended beyond their tipping line.

## MEWP Selection Classifications

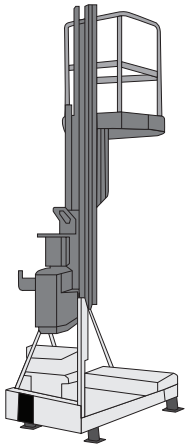
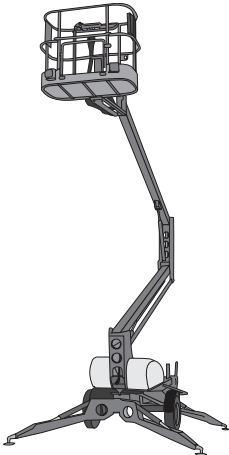
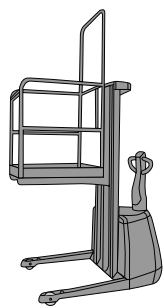
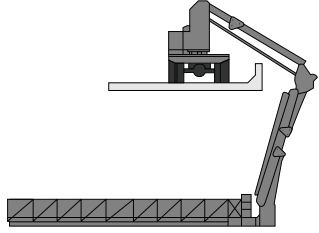
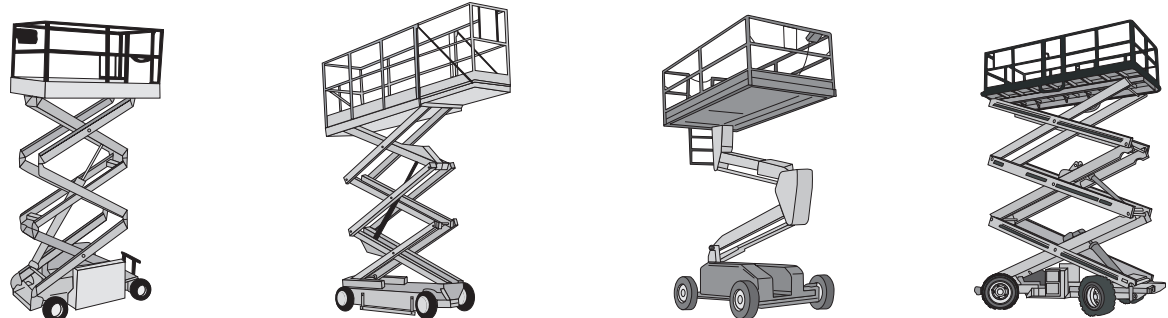
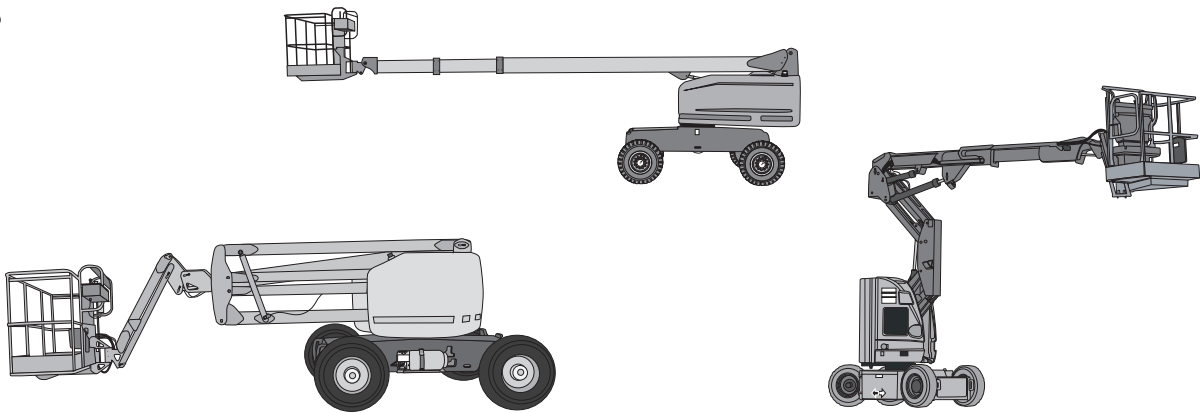
<p>Type 1 Group A</p> 	<p>Type 1 Group B</p> 	<p>Type 2 Group A</p> 	<p>Type 2 Group B</p> 
<p>Type 3 Group A</p> 			
<p>Type 3 Group B</p> 			

## MEWP Selection

### Slab

Slab type MEWPs are typically smaller, electric-powered units with solid tires designed for light-duty, indoor operations on improved driving surfaces that are hard, flat, smooth and level.

### Rough Terrain

Rough Terrain (RT) MEWPs are typically larger, IC engine-powered units with foam or air-filled tires with substantial tread depths designed for heavy-duty, outdoor operations on unimproved roadways that are loose or muddy.

### Manually-propelled

Manually-propelled MEWPs do not have powered drive wheels and must be physically pushed/pulled into position by a person or tow vehicle. MEWPs of this type may also be manually powered meaning they have no powered lift/lower system. The work platform is raised and lowered by a hand-crank connected to a winch.

Manually-propelled vertical lifts (push-arounds) are classified as Type 1, Group A MEWPs. They are economical, easy to transport and compact. Most models can travel through interior doorways and can also go on elevators, depending on the size and load capacity of the elevator.

They must be set up on outriggers or stabilizers and levelled before elevating and are relatively lightweight so they are good for use on floors/driving surfaces with limited load support capabilities.

They are simple and easy for one person to set up and operate.

Available with many options like extra-narrow and insulated work platforms, rough terrain tires, and accessories such as tool trays, fluorescent tube caddy and other material handling devices to customize the lift for all sorts of applications.

Manually-propelled vertical lifts are versatile and useful for applications including indoor building construction repair and maintenance and cleaning.

Trailer-mounted booms (towables) are classified as Type 1, Group B MEWPs. They have a great working range with the up-and-over access of an articulating boom and can easily be towed behind a pickup truck or utility vehicle.

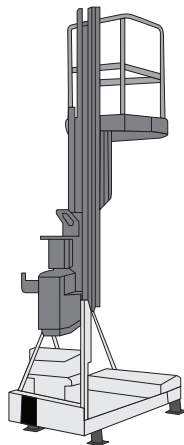

Type 1, Group A  
Manually-Propelled  
"Push Around"

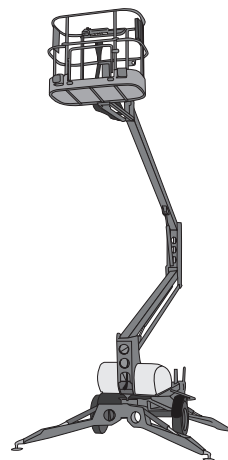

Type 1, Group B  
Manually-Propelled  
"Towable"

A variety of hitch coupler options allow these machines to be towed behind pickups or SUVs while hydraulic outriggers with automatic self-leveling allow an operator to quickly set up the machine for maximum productivity. Users with the appropriate tow vehicle can save on transport fees and the costs involved in operating self-propelled units.

Common applications include home construction, tree trimming and lighting, window washing, signs and mechanical/electrical installation repairs and maintenance.

## MEWP Selection

### Self-propelled

Self-propelled MEWPs have a powered drive system that use either batteries or an internal combustion engine as a power source. Some of the options available within each power source type are AC and DC electric drive systems, engine/battery hybrid drive systems and internal combustion (IC) engines that run on propane (LPG) and/or gasoline as well as diesel engines that run on diesel fuel.

Engine-powered MEWPs are typically used in more heavy-duty applications outdoors where heavier loads are lifted and higher drive speeds are needed. They can be used indoors if there is adequate ventilation to dissipate engine exhaust, in which case propane is the best fuel choice as gas engines running on propane emit less harmful emission levels than those running on gasoline or diesel fuel.

It is worth noting that some gas engines are configured as dual fuel units that can run on either gasoline for outdoor, high output demand operations and can then be switched over to propane for indoor applications.

Regardless of the type of power source, engines and batteries in MEWPs are used to drive either electric drive motors or hydraulic pumps that deliver pressurized fluid to hydraulic motors for drive power. There is no mechanical connection between the power source and the drive wheels.

Single-personnel vertical lifts are classified as Type 3, Group A MEWPs. They are compact, lightweight machines that are able to fit through doorways and in most elevators, in some cases with an operator on the work platform.

They are self-propelled and often have a zero inside turning radius with the ability to drive while elevated which increases efficiency as they can be relocated without lowering. Some models have an extension deck which provides limited reach capability beyond the chassis dimension and a large workspace for up to two operators. Typical applications include warehousing, stock-picking, inventory management and indoor installations, repairs, maintenance and cleaning.

Scissor lifts are also classified as Type 3, Group A MEWPS and they are available in electric and rough terrain models. They are highly maneuverable, self-propelled and have the ability to drive while fully elevated.

Scissor lifts offer either zero degree or high angle turning radius for outstanding maneuverability in tight or congested jobsites, and some electric models are lightweight enough to fit in an elevator, depending on the elevator size and load capacity.

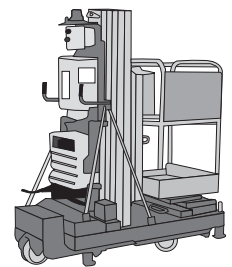

Type 3, Group A  
Single-personnel  
Vertical Lift

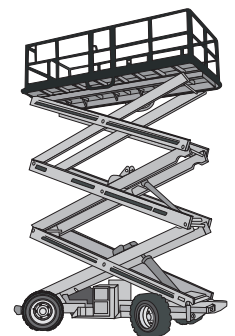

Type 3, Group A  
Scissor Lift

## MEWP Selection

### Self-propelled - continued

Rough terrain scissor lifts are engine-powered machines with large platforms capable of lifting up to 2,500 lb (1,134 kg) depending upon the model. They are built to handle the rigors of the toughest jobsite, and many can be equipped with automatic self-leveling outriggers.

With platform heights from approximate 12 ft (3.6 m) to 50 ft (15 m), these machines are suitable in a variety of applications like indoor/outdoor maintenance and construction, painting and drywall, exterior finishing, rugged worksites, tilt-up construction, warehouse, stock-picking, inventory management, general maintenance and construction.

Aerial boomlifts are classified as Type 3, Group B MEWPs. They fall into two boom design categories, articulating and telescopic.

Articulating booms are MEWPs with several boom sections that hinge or articulate, allowing them to access work areas over obstacles and barriers.

Also referred to as knuckle booms, or up and over booms, these MEWPs are perfect for tight access and hard-to-reach areas, or when reaching over obstacles.

Common applications include indoor construction and maintenance, confined workspaces, outdoor construction, and building maintenance.

Telescopic booms have boom sections that extend telescopically. They are also commonly known as stick booms because they are straight in appearance. Telescopic booms offer greater horizontal reach than all other MEWPs. Well suited to work in areas with limited access, telescopic booms deliver incredible reach and capacity throughout a large working range and outstanding accessibility to elevated work locations.

Rough terrain (RT) boomlifts are often equipped with powerful IC engines, traction-controlled four-wheel drive and oscillating axles designed for maximum traction over non-manufactured roadways or travel paths.

Some models have a work platform load capacity up to 1,000 lb (454 kg) and can accommodate up to three occupants if needed.

Common applications include large construction projects, steel erection, tilt-up slabs, mechanical and electrical installations, manufacturing, and building maintenance.

The proper selection of an appropriate MEWP for the task is critical to the safety of the operator, occupants and others in the work area. Using the wrong machine for the job greatly increases the probability of injury or death, damage to the machine itself, or damage to the work location.

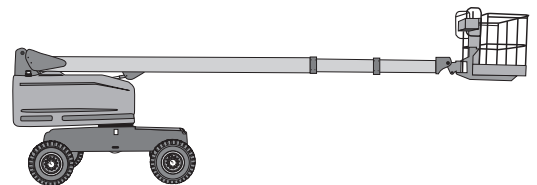

Type 3, Group B Telescopic Boomlift

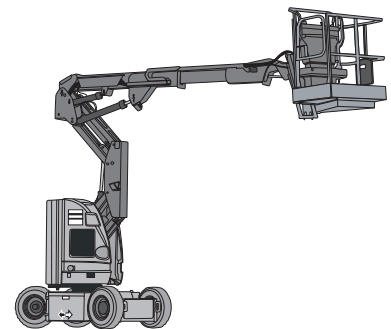

Type 3, Group B Articulating Boomlift

The following features and options are some of the key factors you should consider before selecting a machine for a job:

## **Tire/Track Options**

### **Non-marking Tires**

These are creamed-colored tires that are made without the carbon that makes regular tires appear black. They leave no marks on the floor and are commonly made of hard rubber. These tires are good for indoor use where marking the floor is a concern.

### **Foam-filled Tires**

Pneumatic tires that are injected with a polyurethane-type substance that adds stiffness to the tires and prevents flats. These are required on some models to provide ballast for stability. These tires are also good for environments with nails and other ground debris as they will not go flat if punctured.

### **Rough-terrain Tires**

Tires with an aggressive tread design for improved traction over non-improved, rough-terrain roadways.

### **Fixed Tracks**

A drive track/belt system that provides extra traction and support when traveling over mud, sand, gravel and soft-soil conditions while minimizing damage to driving surfaces. MEWPs fitted with tracks are often called crawler units.

## **Rough Terrain Options**

### **Rough Terrain (RT) Model**

A MEWP designed to travel over non-improved driving surfaces or roadways. This type of surface is typically made by digging/scraping a path into the ground or pouring materials like gravel, road mulch or wood chips etc. on top of the ground to create a usable driving surface. Alternatively, an improved driving surface is a purpose-built, engineered driving surface usually made of concrete or asphalt that is generally hard, flat, level and clear of debris.

Some units are designated as RT models by the manufacturer based solely on the addition of lug tread tires. However, other RT features may include:

### **High Output IC Engine**

Internal combustion engines with greater horsepower and or torque ratings for high load demand applications.

### **Two/Four-wheel Drive and Steer Options**

Features that improve the traction and maneuverability of the MEWP.

### **Oscillating Axles**

Axles that pivot in the middle to compensate for uneven terrain and keep all drive tires in contact with the ground.

### **Drive Axle Lock Control**

An option that can be engaged in loose, muddy conditions that locks the drive axle(s) to maintain full time two/four-wheel drive, even if one wheel loses traction.

## Range of Motion and Restricted Capacity Zones

The working range that boomlifts can access is determined by a combination of its height and outreach capabilities — commonly referred to as its range of motion or working envelope. Range of Motion charts with an image on a grid illustrating the unit's effective working area are often provided on aerial boomlifts.

Some boomlifts may also have restricted capacity zone charts that specify alternative load ratings based on the unit's height/reach specifications.

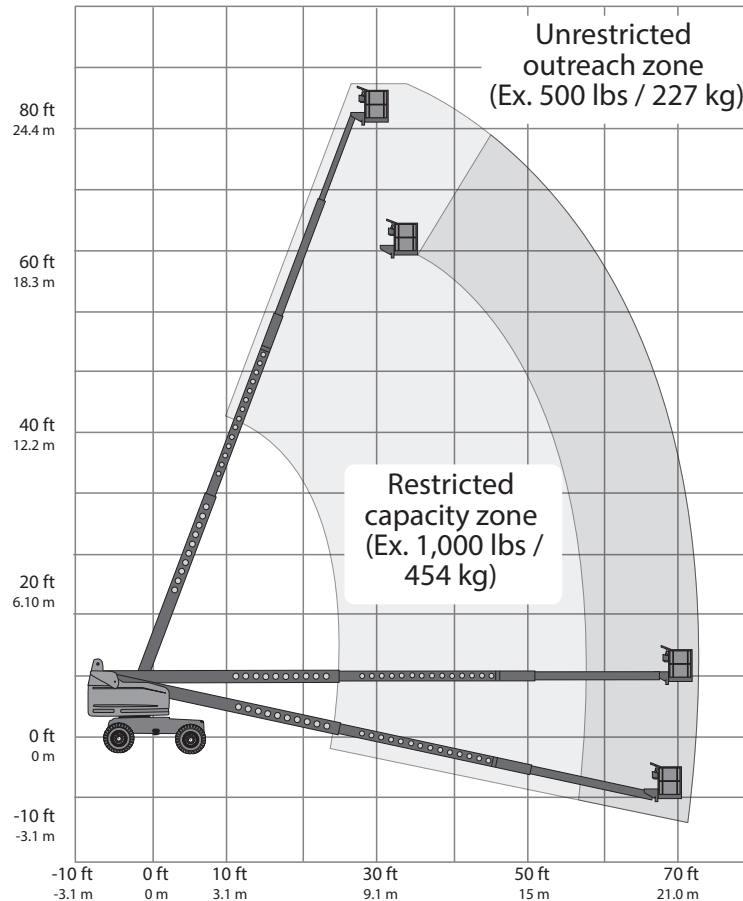

## Work Platform Height vs. Working Height

MEWP specifications often reference work platform height and working height dimensions. Work platform height is the maximum height in feet and/or meters from the supporting surface of the MEWP to the deck of the work platform. Working height is six feet or two meters higher than that, which is a distance equal to the reach of an average person standing on the deck with arms reaching overhead. So the working height of a unit rated at a 135 ft (41.15 m) work platform height is 141 ft (43.15 m). The metric equivalent of actual working height adds two meters to work platform height.

**NOTE:** Check the manufacturer's operation manuals stored on the MEW for accurate information on your unit.

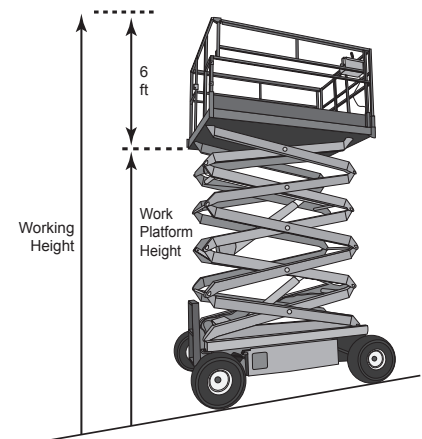

## MEWP Selection

To help identify the correct MEWP for a given task, look for answers to the following questions:

### Worksite

- a) Where will the equipment be used?
  - i. Indoors:
    - Limited operational area/low and/or narrow doorways.
    - Obstacles: Ground/Floor obstructions and/or high-mounted/suspended fixtures, appliances or ductwork/conduit, plumbing.
    - Fluids on floor.
    - Ramps.
    - Ventilation.
  - ii. Outdoors:
    - Ground/Surface support conditions.
    - Slopes/Grades.
    - Weather conditions.
  - iii. Both:
    - Pedestrian/Vehicle traffic.
    - Hazardous goods/flammable/caustic/toxic materials/environments.
    - Refueling/Charging.
    - Debris.
    - Transport.

### The Task

- a) Type of work to be performed.
- b) Expected load weight/size.
- c) Occupancy requirement.
- d) Are tools and/or accessories needed?
- e) How high do you need to go?
- f) How far do you need to reach/extend?

## The MEWP

- a) Slab.
- b) RT.
- c) Scissor/Vertical lift:
  - i. Manually-propelled.
  - ii. Self-propelled.
- d) Boomlift:
  - i. Manually-propelled.
  - ii. Self-propelled.
  - iii. Telescopic boom.
  - iv. Articulated boom.

## Personnel

### Operator/Occupant

- a) Trained.
- b) Familiarized.
- c) Authorized.
- d) Qualified for specialty work (Trades/Power tools/Accessories/Other).

### Ground Personnel

- a) Trained/Qualified personnel with knowledge in use of equipment-specific emergency lowering controls/systems.
- b) Trained/Qualified rescue personnel capable of retrieving stranded/incapacitated work platform occupants.
- c) Trained supervisors knowledgeable in the planning, executions and monitoring of MEWP operators and operations.

## MEWP Selection Guideline Table (SUP-190-e)

This table (see following page) may be used to help assess the factors involved in choosing the proper MEWP for a given task. Keep in mind that it is only a guideline to assist in the MEWP selection process and should not be used as a definitive decision making tool.

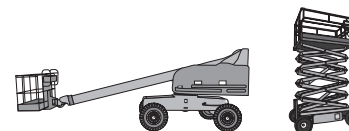

MEWPs Selection Guideline Table								
Parameters		Slab	RT	TBL	ABL	SL	MVL	MBL
Indoor (IR)		√	Y	Y	√	√	√	√
Outdoor (IR)		√	√	√	√	√	Y	√
Outdoor (NR)		X	√	√	√	√	X	Z
Load Weight Requirement	Over 500 lb	√	√	√	√	√	√	√
	Up to 500 lb	√	√	√	√	√	Z	Z
	Over 500 lb	√	√	Z	Z	Z	X	√
Occupancy Needed	1	√	√	√	√	√	√	√
	1 or 2	√	√	√	√	√	Z	Z
	3 or more	√	√	X	X	√	X	√
Reach Requirement	Up to 3 feet	√	√	√	√	Z	X	√
	Over 3 feet	√	√	√	√	√	X	√
Height Requirement NOTE: Use MVL unit where low stowed <sup>0</sup> height is required.	Up to 20 feet	√	√	√	√	√	Z	√
	Up to 60 feet	Z	√	√	√	√	Z	Z
	Up to 120 feet	Z	√	√	√	√	X	Z
	Over 120 feet	Z	√	√	√	X	X	X
Use of Accessories Required		Z	Z	Z	Z	√	Z	Z

- RT Rough Terrain √ OK
- TBL Telescopic Boomlift X Not Recommended/Prohibited
- ABL Articulated Boomlift Y Possible in certain situations but not ideal
- SL Scissor Lift Z Check Manufacturer's Specifications
- MVL Manually-propelled Vertical Lift IR Improved Roadway\*
- MBL Manually-propelled Boomlift NR Non-improved Roadway^

\* A purpose-built, engineered driving surface usually made of concrete or asphalt that is generally hard, flat, level and clear of debris.

^ A driving surface that is made by digging/scraping a path into the ground or pouring materials like gravel, road mulch or wood chips etc. on top of the ground to create a usable driving surface.

<sup>0</sup> Maximum height with all moveable sections retracted and lowered.

**NOTE: This chart is a guideline only and references commonly available, non-customized equipment being used for typical, non-specialized applications. Consult the MEWP manufacturer's make and model-specific operation manuals for exact specifications, intended use information or other information as required.**

**NOTE: This chart is available for download at [www.ivestraining.com](http://www.ivestraining.com).**

## **MEWP Occupant Knowledge Checklist (SUP-182-e)**

As is the case with operators, employers/users must ensure that MEWP work platform occupants receive training to become knowledgeable on how to work safely on a MEWP. Operators must confirm that occupants have the knowledge needed and either be able to provide instruction if an occupant's knowledge is lacking or direct the occupant where to find the instruction/training to acquire the knowledge needed to work safely on a MEWP.

This instruction does not give occupants the skills or authorization to operate the MEWP, only the knowledge of how to work safely on it and, in some cases, how to use the controls to lower the work platform in an emergency.

Refer to the SAMPLE MEWP Occupant Knowledge Checklist on the following page and use it as a quick reference to assist in complying with the occupant knowledge requirements detailed in the standards. Occupants must not go up in a MEWP until they are knowledgeable and in full understanding of all the items on the checklist.

## **MEWP Safe Use Checklist (SUP-187-e)**

This checklist (see SAMPLE on page 29) serves as a quick reference to help you comply with the requirements for a safe use plan detailed in the standards. This checklist should only be used in combination with a formal site risk assessment.

### SAMPLE MEWPs Occupant Knowledge Checklist (SUP-182-e):

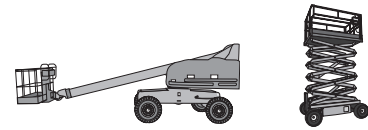

MEWPs Occupant Knowledge Checklist				
OCCUPANT NAME: <i>Terry Sawchuck</i>		OCCUPANT EMPLOYER NAME: <i>Danforth Wheel Co. Inc.</i>		
MEWP TYPE/MAKE/MODEL: <i>3B MegaLift 2604AJ</i>		CHECKLIST COMPLETED BY: <i>Darcy McBride</i>		
OCCUPANT SIGNATURE: <i>[Signature]</i>		DATE: <i>May 24, 2025</i>		
Item				Comments
<b>1) Fall Protection:</b>				
	YES	NO	N/A	
a) Understands purpose of guardrails.	<input checked="" type="checkbox"/>	<input type="checkbox"/>	<input type="checkbox"/>	
b) Understands use requirements for PFPS*.	<input checked="" type="checkbox"/>	<input type="checkbox"/>	<input type="checkbox"/>	
c) Knowledgeable of arrest vs. restraint.	<input checked="" type="checkbox"/>	<input type="checkbox"/>	<input type="checkbox"/>	
d) Can identify harness/lanyard/anchor.	<input checked="" type="checkbox"/>	<input type="checkbox"/>	<input type="checkbox"/>	
e) Can calculate clearance requirement.	<input type="checkbox"/>	<input type="checkbox"/>	<input checked="" type="checkbox"/>	<i>- Restraint system used</i>
f) Understands PFPS labels/ratings/specs.	<input checked="" type="checkbox"/>	<input type="checkbox"/>	<input type="checkbox"/>	
g) Able to properly inspect components.	<input checked="" type="checkbox"/>	<input type="checkbox"/>	<input type="checkbox"/>	
h) Able to properly don harness.	<input checked="" type="checkbox"/>	<input type="checkbox"/>	<input type="checkbox"/>	
i) Can identify & connect to suitable anchorage.	<input checked="" type="checkbox"/>	<input type="checkbox"/>	<input type="checkbox"/>	
j) Other:	<input type="checkbox"/>	<input type="checkbox"/>	<input checked="" type="checkbox"/>	
<b>2) Safe Work Procedures; Understands reasons to avoid:</b>				
	YES	NO	N/A	
a) Horseplay/Abrupt movements.	<input checked="" type="checkbox"/>	<input type="checkbox"/>	<input type="checkbox"/>	
b) Climbing on guardrails.	<input checked="" type="checkbox"/>	<input type="checkbox"/>	<input type="checkbox"/>	
c) Leaning too far beyond guardrails.	<input checked="" type="checkbox"/>	<input type="checkbox"/>	<input type="checkbox"/>	
d) Not maintaining firm footing.	<input checked="" type="checkbox"/>	<input type="checkbox"/>	<input type="checkbox"/>	
e) Leaning over/touching the MEWP controls.	<input checked="" type="checkbox"/>	<input type="checkbox"/>	<input type="checkbox"/>	
f) Exceeding load/occupancy ratings.	<input checked="" type="checkbox"/>	<input type="checkbox"/>	<input type="checkbox"/>	
g) Poor load weight distribution.	<input checked="" type="checkbox"/>	<input type="checkbox"/>	<input type="checkbox"/>	
h) Handling large objects (sails).	<input type="checkbox"/>	<input type="checkbox"/>	<input checked="" type="checkbox"/>	
i) Pushing/Pulling objects outside the work platform.	<input checked="" type="checkbox"/>	<input type="checkbox"/>	<input type="checkbox"/>	
j) Misusing the MEWP beyond its intended purpose/design.	<input checked="" type="checkbox"/>	<input type="checkbox"/>	<input type="checkbox"/>	
k) Leaving/Exiting an elevated work platform.	<input type="checkbox"/>	<input type="checkbox"/>	<input checked="" type="checkbox"/>	<i>- Co. policy</i>
l) Other:	<input type="checkbox"/>	<input type="checkbox"/>	<input checked="" type="checkbox"/>	
<b>3) Specific Knowledge &amp; Understanding of:</b>				
	YES	NO	N/A	
a) Use accessories as required.	<input type="checkbox"/>	<input type="checkbox"/>	<input checked="" type="checkbox"/>	<i>- None used</i>
b) Site/Task-specific safe work procedures & PPE requirements.	<input checked="" type="checkbox"/>	<input type="checkbox"/>	<input type="checkbox"/>	
c) Manufacturer's equipment-specific warnings, decals, labels & instructions.	<input checked="" type="checkbox"/>	<input type="checkbox"/>	<input type="checkbox"/>	
d) Location/Use manufacturer's operation manuals.	<input checked="" type="checkbox"/>	<input type="checkbox"/>	<input type="checkbox"/>	
e) All information communicated as per safe use plan/site risk assessment.	<input checked="" type="checkbox"/>	<input type="checkbox"/>	<input type="checkbox"/>	
f) Use MEWP controls to lower work platform as needed.	<input checked="" type="checkbox"/>	<input type="checkbox"/>	<input type="checkbox"/>	
g) Other:	<input type="checkbox"/>	<input type="checkbox"/>	<input checked="" type="checkbox"/>	

\* Personal fall protection system.

NOTE: Blank/Fillable copies of this form available at [www.ivestraining.com](http://www.ivestraining.com).

### SAMPLE MEWPs Safe Use Checklist (SUP-187-e)

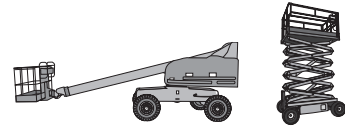

MEWPs Safe Use Checklist				
COMPANY NAME: <i>Impact Drilling LLC</i>		BRANCH/LOCATION: <i>Danforth Wheel Co. Inc.</i>		
JOBSITE LOCATION: <i>North Maintenance Building</i>		DATE: <i>May 24, 2025</i>		
ASSESSOR(S) NAME/CONTACT INFO.: <i>Sandy Burke - 789-738-2020 sburke@impactdrill.com</i>				
ITEM	ISSUES			COMMENTS
	YES	NO	N/A	
<b>1. Site Risk Assessment:</b>	YES	NO	N/A	
a) Hazards identified.	✓			
b) Risks evaluated.	✓			
c) Control measures developed.	✓			
d) Safety procedures communicated.	✓			- @ Operations crew meeting
e) Other:			✓	<i>05/05/20</i>
<b>2. Worksite Inspection:</b>	YES	NO	N/A	
a) Drop-offs/Holes.		✓		
b) Bumps & floor/ground obstructions.		✓		
c) Debris.		✓		- Sweeper used before shift
d) Overhead obstructions.	✓			- MEWP crew advised
e) Electrical conductors.	✓			- MEWP crew advised (MAD used)
f) Hazardous locations.		✓		
g) Ramps/Slopes.	✓			- Within MEWP Specs-Crew advised
h) Ground surface & support conditions.		✓		
i) Pedestrian/Vehicle/Equipment traffic.	✓			- Barricades used
j) Weather conditions.			✓	- Indoor
k) Other:			✓	
<b>3. MEWP:</b>	YES	NO	N/A	
a) Suitable type selected.	✓			- 3A Superlift 32/20E (Unit 1)
b) Inspected/Maintained as required.	✓			
c) Protect from unauthorized use.	✓			
d) Accessories/Other equipment suitable.			✓	
e) Proper records/documentation retained.	✓			
f) Other:		✓		
<b>4. Personnel:</b>	YES	NO	N/A	
a) Operators trained/familiarized/authorized.	✓			
b) Occupants trained.	✓			
c) Supervisors trained.	✓			
d) Rescue personnel trained & designated.	✓			
e) Non-MEWP personnel trained/aware.	✓			
f) Other:			✓	

**NOTE: Blank/Fillable copies of this form available at [www.ivestraining.com](http://www.ivestraining.com).**



TRAINING GROUP

*Training that works where you do!*

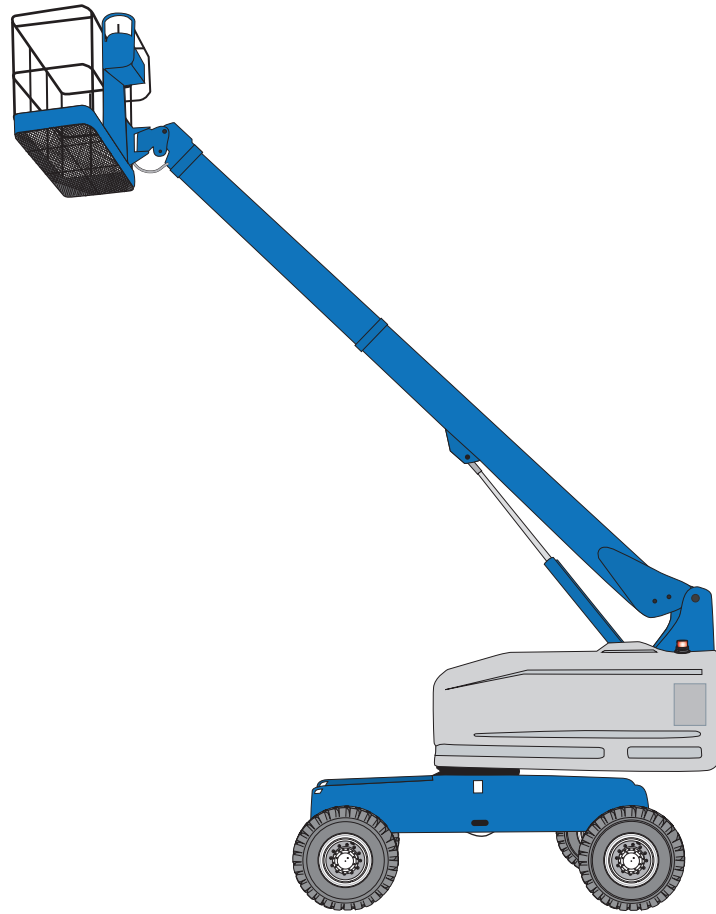
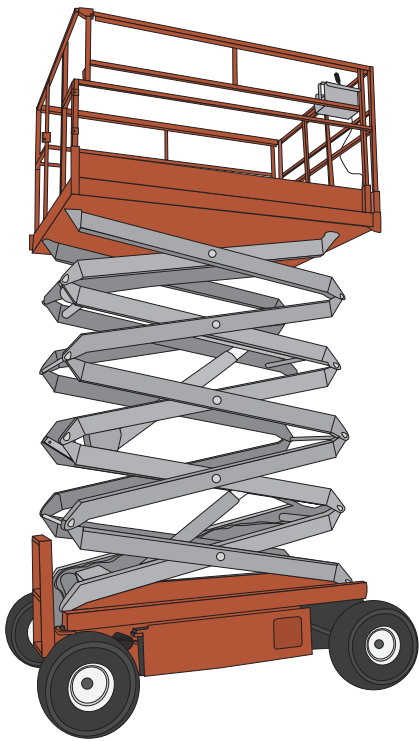

If you have any questions, please contact IVES Training Group at:

**Toll-free**

1.800.643.1144

**Tech support**

[askbob@ivestraining.com](mailto:askbob@ivestraining.com)

**General enquiries**

[info@ivestraining.com](mailto:info@ivestraining.com)